

Telephone HOOD

Model: RF-11



Main features

- Designed for use in noisy areas and harsh environments
- Extremely robust
- Good acoustic qualities and highly visible
- To protect inside telephone waterproof
- Popular in noisy factories such as newspaper print rooms.



Specification

Color	Transparent Blue/Yellow available
Material	Organic glass
Dimensions	H600* W500* D340mm
Weight	Approx 4Kg
Shipment Packing details	
Shipping Carton Box	2pcs in 1box and box size: 765x530x365mm G.W:24.8Kg

Size Display

Unit: mm

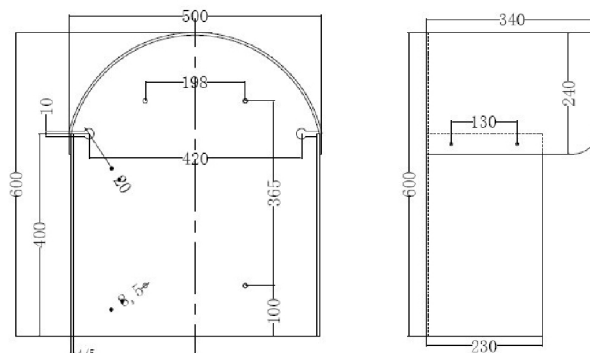

Web: www.koontech.com

Email: marketing@koontech.com

Tel: (HK Office) +852 9068 2799 / (Shenzhen Office) +86 755 2744 8753

Shenzhen Office: 1001 Block A Building T3, Yifang Center, Bao'an, Shenzhen, Guangdong, China

HK Office: Unit C, 2/F, Ka To Factory Building, 2 Cheung Yue Street, Cheung Sha Wan, Kowloon, Hong Kong

Factory: KNTECH Building, Phoenix Mountain, Limhai Zone, Shajiao Community, Humen, Dongguan, China