



**Analogue KNZD-14 Hotline Phone**

**DESCRIPTION ITEM NO.:ZD0140012**

1. Cold-roll steel body for easy Installation.
2. Waterproof rating IP55 dust proof.
3. Without keypad, support hot-line calling.
4. Weather resistant to IP55 standard, service temperature range from -30 degree to +75 degree.
5. Lightening protection to ITU-T recommendation K.21.
6. Heavy Duty handset with hearing Aid compatible receiver, Noise canceling microphone.
7. Handset with industrial strong armored cord .
8. Phone integrity wiring to enable the telephone system to check if the telephone unit is still Operational.(If PABX have this available we can provide this function).
9. Optional 7 minute time out to release the line if the handset is left off hook. This function upon buyer's requirement).
10. Powder coated in UV stabilized polyester finish.
11. The housing covered with a layer of reflective label for easy identification at night.Optional
12. Application: Tunnel, metro, railway, LRT, speedway, marine, ship,offshore, mine, power plant, bridge etc.



**SPECIFICATION**

1. PSTN analogue telephone
2. DTMF dialing
3. MTBF:100000hours
4. MTTR: 2 hours
5. Connection: RJ11 screw terminal pair cable
6. Applicable for various types of SPC exchange PABX and dispatching exchange system with feeding voltage of 33-60V.
7. Ambient temperature:-30 ~ +60 degree. Relative humidity:10%~95%  
Atmospheric pressure: 86~106Kpa Circumstance noise:less than 60dB(A)
8. Sound level of ringing:over 70dB(A).
9. Standard frequency:low frequency group:697. 770. 852. 941Hz,  
high frequency group:1209. 1336. 1477Hz, frequency deviation:-1.5% ~ +1.5%
10. Call transmission index:(5KM)SLR<12,RLR<-1,STMR>10, output impedance is 600 Ohm.  
maximum distance: 7KM
11. Hotline setting (maximum length of each number is 16 digits).
12. Connection: RJ11 screw terminal pair cable (or RJ11 Socket of plug upon request) with stainless steel protected

**CERTIFICATION**

EN55022: emissions

EN55024: immunity

Ingress Protection: GB4208-93 IP66 FCC

ITU-T Recommendations K21

EMC: EN50121(Railway application-Electromagnetic Compatibility)

**RoHS****PACKING**

Unit size:240\*130\*35mm Unit: N.W:1.36KG

1pcs packing box size: 310\*170\*130mm Unit N.W:1.36KG Unit G.W:2KG

# INSTALLTION

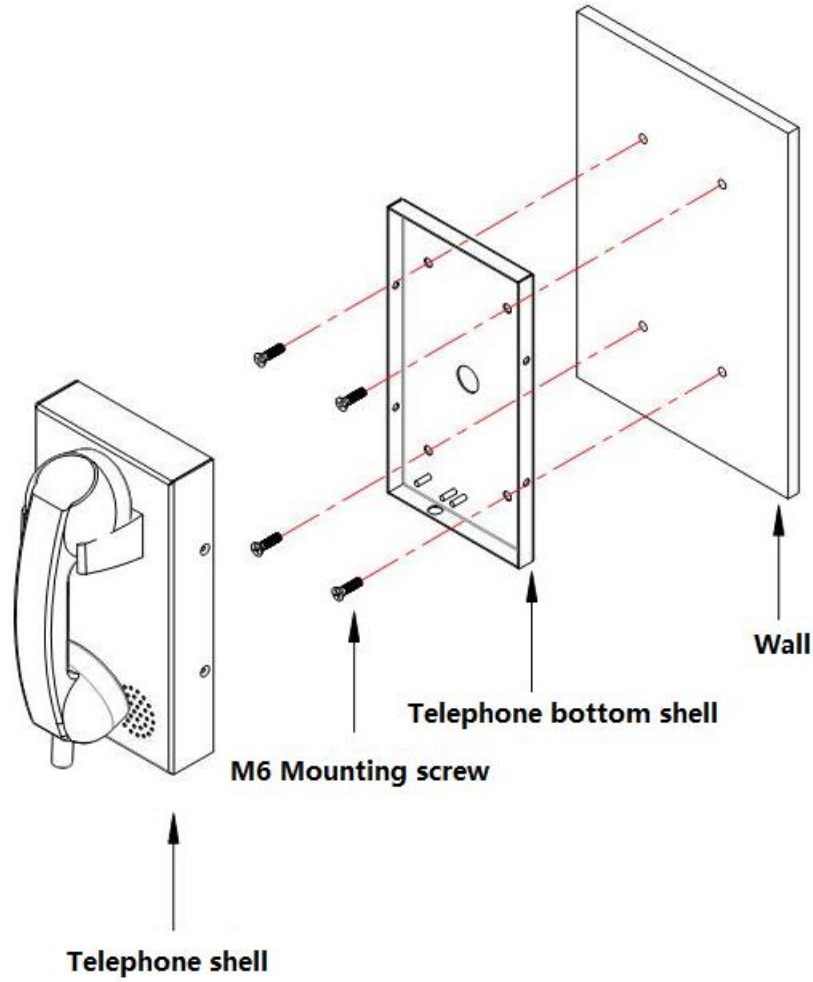

**Unit:mm**

