



Analogue KNSP-18 Waterproof Telephone

DESCRIPTION

1. Robust SMC 2600 glass fibre reinforced polyester die-cast body, Vandal & tamper-resistant hardware, easy Installation.
2. Waterproof rating IP66 dust proof.
3. Full keypad 0~9 with hand-free, redial, speed-dial.
4. LCD display show the dialing number.
5. Weather resistant to IP66 standard, service temperature range from -30 degree to +75 degree.
6. Magnetic reed hook-switch.
7. Lightening protection to ITU-T recommendation K.21.
8. Heavy Duty handset with hearing Aid compatible receiver, Noise canceling microphone.
9. Handset with industrial strong armored cord .
10. Stainless steel keypad keep waterproof and dusty proof.
11. Phone integrity wiring to enable the telephone system to check if the telephone unit is still operational.(if PABX have this available we can provide this function).
12. Optional 7 minute time out to release the line if the handset is left off hook. This function upon buyer's requirement).
13. Powder coated in UV stabilized polyester finish.
14. Application: Tunnel, metro, railway, LRT, speedway, marine, ship, offshore, mine, power plant, bridge etc.



SPECIFICATION

1. PSTN analogue telephone
2. DTMF dialing
3. MTBF:100000hours
4. MTTR: 2 hours
5. Connection: RJ11 screw terminal pair cable
6. Applicable for various types of SPC exchange PABX and dispatching exchange system with feeding voltage of 33-60V.
7. Ambient temperature:-30 ~ +60 degree. Relative humidity:10%~95%
Atmospheric pressure: 86~106Kpa Circumstance noise:less than 60dB(A)
8. Sound level of ringing:over 70dB(A).
9. Standard frequency:low frequency group:697. 770. 852. 941Hz,
high frequency group:1209. 1336. 1477Hz, frequency deviation:-1.5% ~ +1.5%
10. Call transmission index:(5KM)SLR<12,RLR<-1,STMR>10, output impedance is 600 Ohm.
maximum distance: 7KM
11. Connection: RJ11 screw terminal pair cable (or RJ11 Socket of plug upon request) with stainless steel cable protected

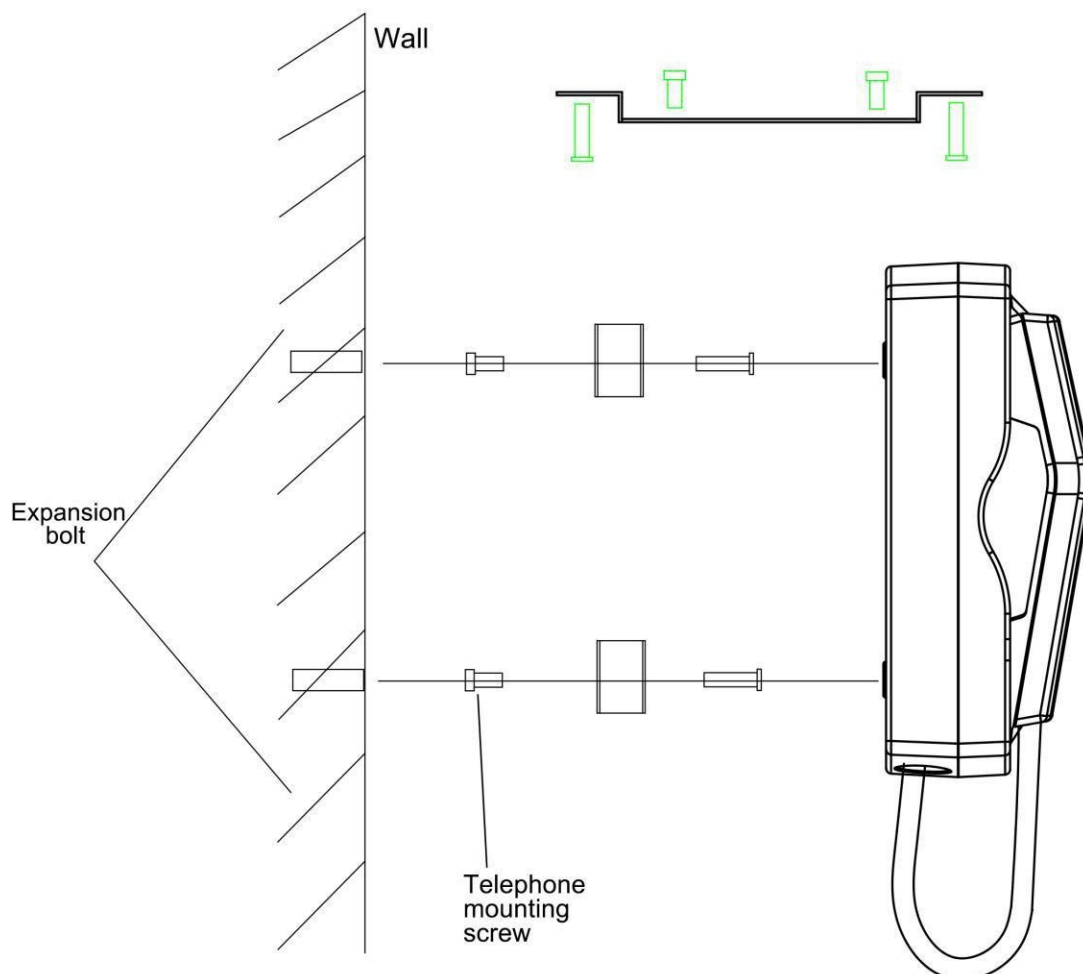
INSTALLATION

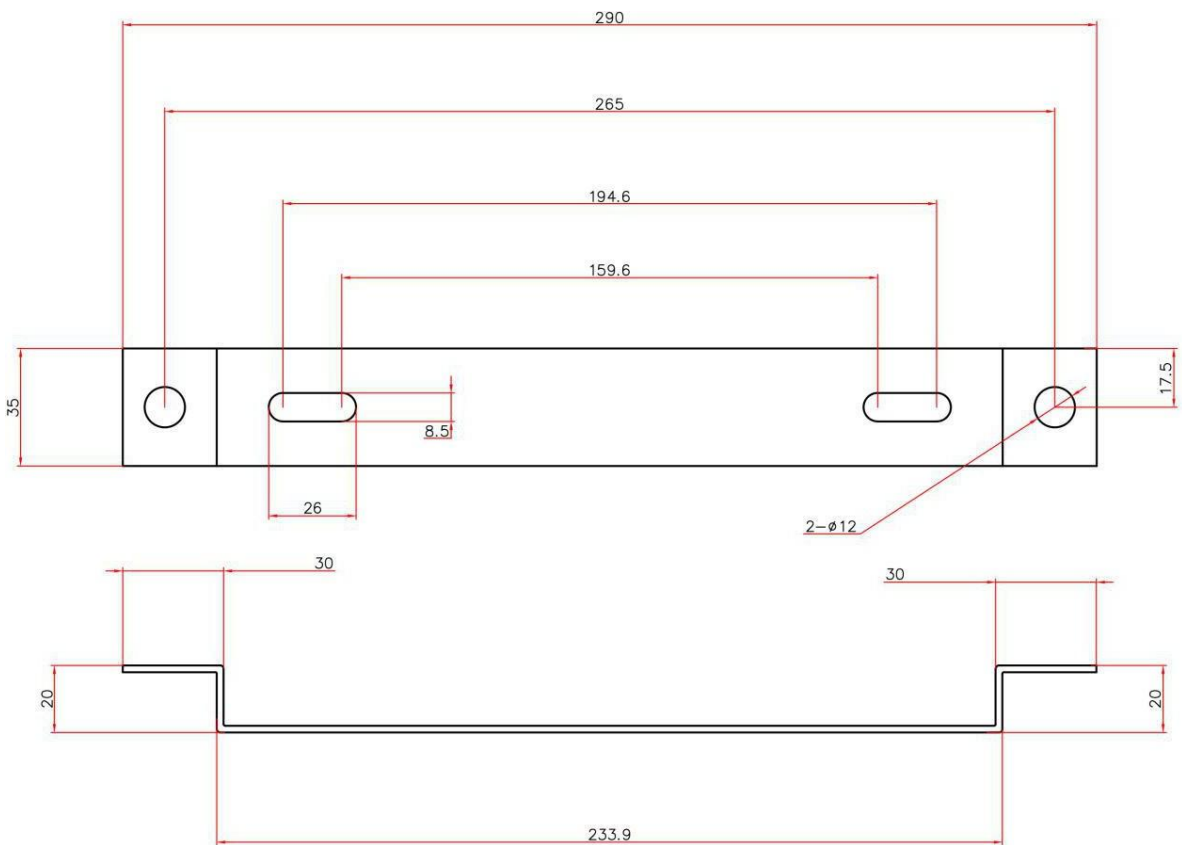
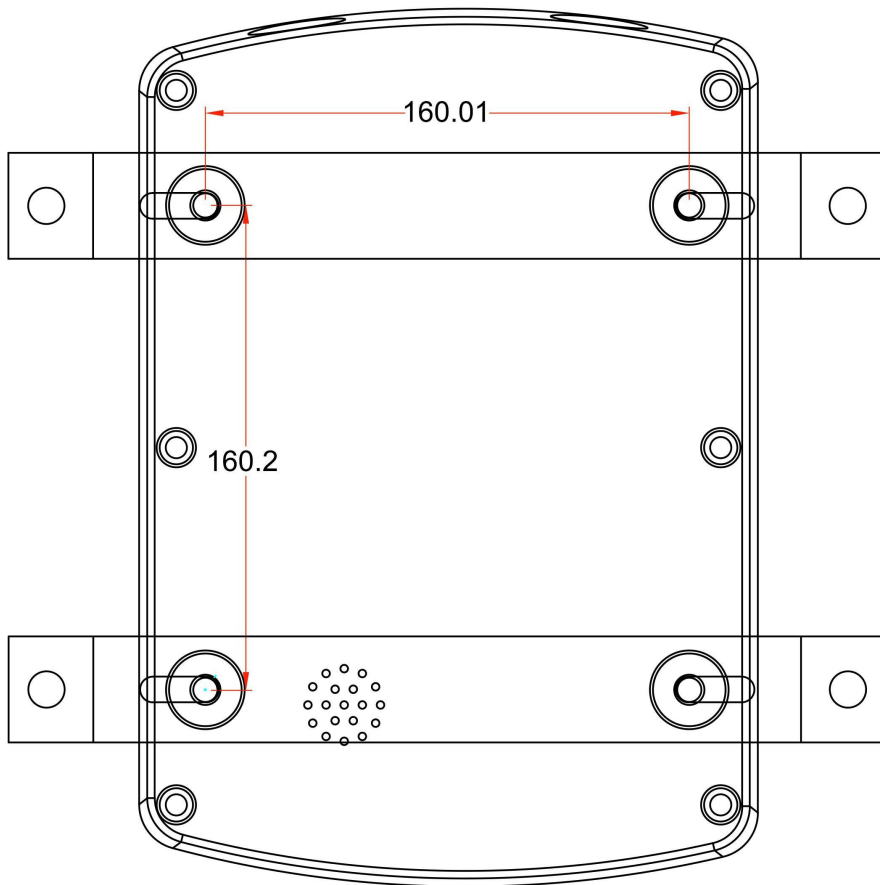

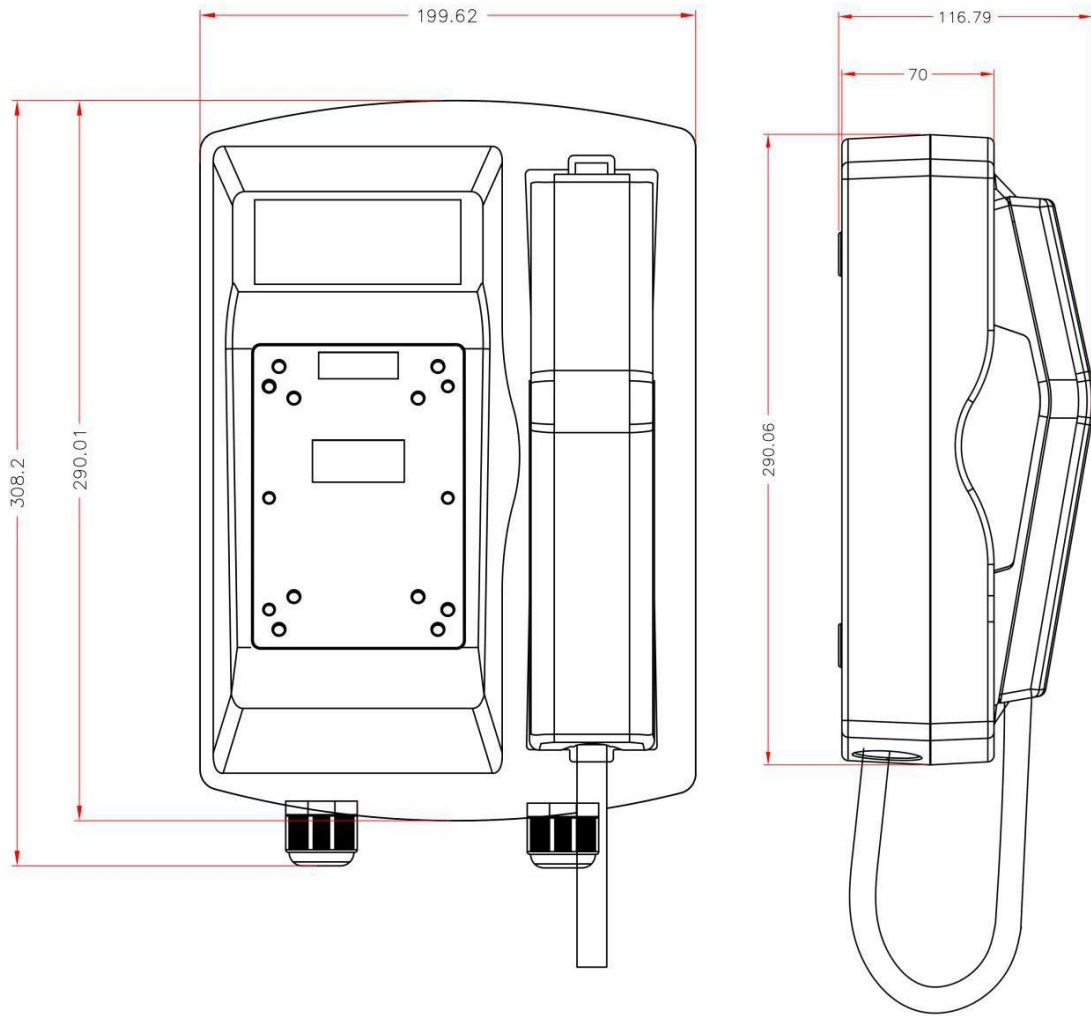

CERTIFICATION



PACKING



Unit size:290 *205*117mm N.W: 3.9KG

1pcs packing box size: 439*277 *191mm N.W: 3.9KG G.W: 5.7KG

6pcs in 1 outer Carton box: size: 730*390*340mm N.W: 23.4KG G.W: 29.6KG



HONGKONG KOON TECHNOLOGY LTD

TEL:0086755 29790158/27448753 Fax:0086755 29790278
 Email:marketing@koontech.com www.koontech.com