

昆仑科技

www.koontech.com

香港昆仑科技(深圳)有限公司

Regular Customer

THALES SIEMENS



Alcatel-Lucent



HUAWEI

ERICSSON
TAKING YOU FORWARD

AVAYA
The Power of We



Emergency telephone SUS KNZD-07A



The most professional manufacture in Asia The exclusive supplier for all Metro project in China

The emergency call telephone will be designed to work on railway, metro, tunnel, etc. Housed in stainless steel box with one CALL/ ANSWER button, it will offer protection against the outdoor environment and vandals. The unit will meet all the latest European/UK standards telephony, waterproofing IP65, and lightning protection together with offering the level of performance and reliability demanded in such an environment.

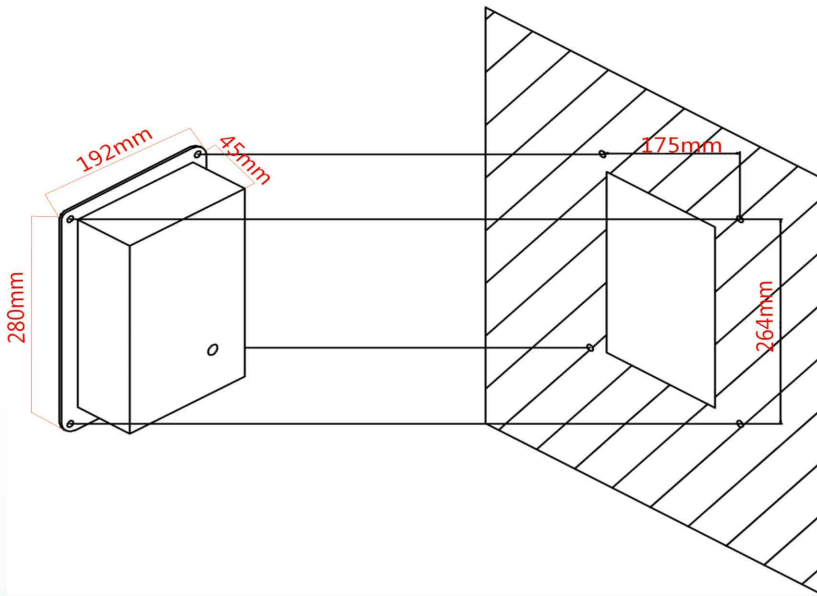

- Standard and SMART Analogue and VoIP-SIP options available
- DTMF(Dual Tone Multi Frequency)
- Matching with most PABX,PBX and PAX systems.

Main Product features

1. High waterproof, dustproof performance, SUS304 full stainless steel body, protection grade reaches to IP65.
2. High durability, oil, acid, alkali resistance, conform to the standards of GJB - 773 and UL1332 requirements.
3. The box with earthing device is completely isolated with internal electric circuit, and has certain electromagnetic shielding effect.
4. Conversation with clear loud voice, no feedback screaming.
5. Support hotline of exchange system.
6. Support the function of exterior line automatic lift.
7. Support conversation time limited.
8. Strong, thick and beautiful body with embed wall design.

Main PCB

1. Well treated PCB used inside the phone.
2. Robust screw terminals used for the connection of ringer, handset, line in, hookswitch.
3. Selectable 7 minute time out, to release the line if the handset is left off hook.
4. All connectors be greased in production.

Handset

1. Kirk electro dynamic transducer for both handset transmitter and receiver
2. Spring cable or armoured cable to attach the handset to the telephone main unit
3. Stainless steel cable to connect exchange.
4. Inductive coupler fitted for hearing aid compatibility.
5. Handset integrity wiring to enable exchange to check if the phone is still operational.

VOIC OVER IP- SIP (Version)

Connection type: RJ45 Socket inside sealed enclosure
 Power supply: External 5V dc
 Call set-up Protocol: Session Initiation Protocol(SIP)
 Configuration: DHCP or STATIC IP address provisioning



The most professional manufacture in Asia
The exclusive supplier for all Metro project in China

Telephone layout

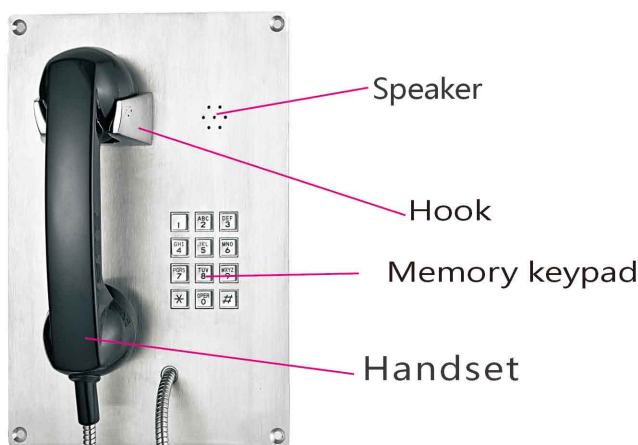

Mounting bracket

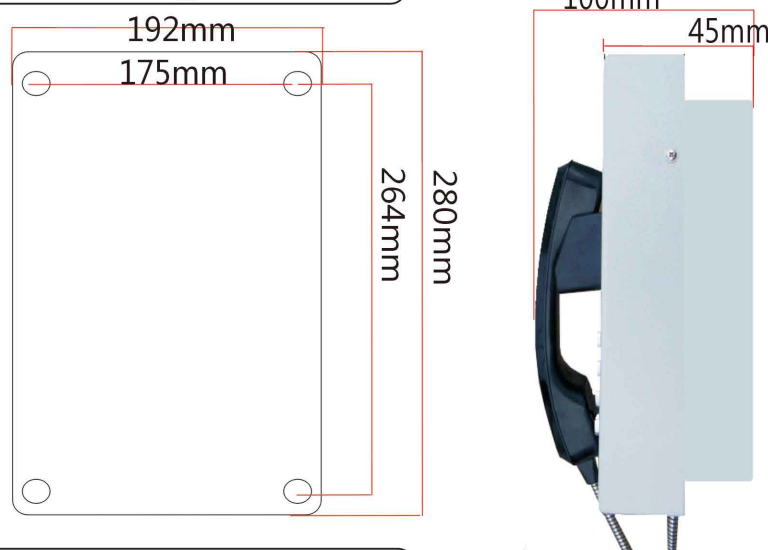

Connection cable

Stainless steel connection cable to exchange.
 Well treated keep waterproof.

Packing detail:



Unit size: 280*192*100mm , N.W: 2.5KG
 1pcs in each inner CTN box, size: 300*200*80mm G.W: 3.21KG
 6pcs in outer CTN box, size: 745*410*330mm G.W: 19.56KG

Certification:



EMC: EN50121 (Railway application-
 Electromagnetic Compatibility)
 EN55022: emissions
 En55024: immunity

FCC
 ITU-T Recommendations K21

TECHNICAL SPECIFICATION

1. It is suitable for automatic instruction amplification telephone system when feed voltage reaches to 33- 60V.
2. Environmental temperature: -30°C ~ 60°C
3. Relative humidity: 10% ~ 95%
4. Atmospheric pressure: 86 ~ 106Kpa
5. Environmental noise: ≤80dB
6. Double audio dialing
7. Standard frequency: 697, 770, 852, 941Hz
8. Low frequency group: 697, 770, 852, 941Hz
9. High frequency group: 1209, 1336, 1477Hz
10. Frequency offset: ≤ ±1.5%
11. The signal level when the length of user's line is 3km:
12. Standard frequency: Low frequency group: -9dB
13. High frequency group: -7dB±3dB
14. Level difference between high and low frequency of combined signal: 2±1dB
15. The total intermodulation distortion caused by harmonic is 20dB lower than wave level.
16. Call transmission index: (5Km) SLR ≤ 12, RLR ≤ -1, and STMR ≥ 10, Input impedance: 600Ω