

昆仑科技

www.koontech.com

香港昆仑科技(深圳)有限公司

Regular Customer

THALES SIEMENS



Alcatel-Lucent



HUAWEI

ERICSSON
TAKING YOU FORWARD

AVAYA
The Power of We



Optional Induction loop facility for hearing impaired
12V DC required
Hongkong Koon Technology Ltd
www.koontech.com



Emergency telephone SUS KNSD-100



The most professional manufacture in Asia The exclusive supplier for all Metro project in China

The emergency call telephone also called elevator telephone, bank service phone, emergency phone, Railway phone, metro phone, tunnel telephone, airport service phone, hospital help phone, kiosk telephone, school or university, Housed in robust aluminium box with one CALL/ ANSWER button, it will offer protection against the outdoor environment and vandals.

The unit will meet all the latest European/UK standards telephony, waterproofing IP55, and lightning protection together with offering the level of performance and reliability demanded in such an environment.

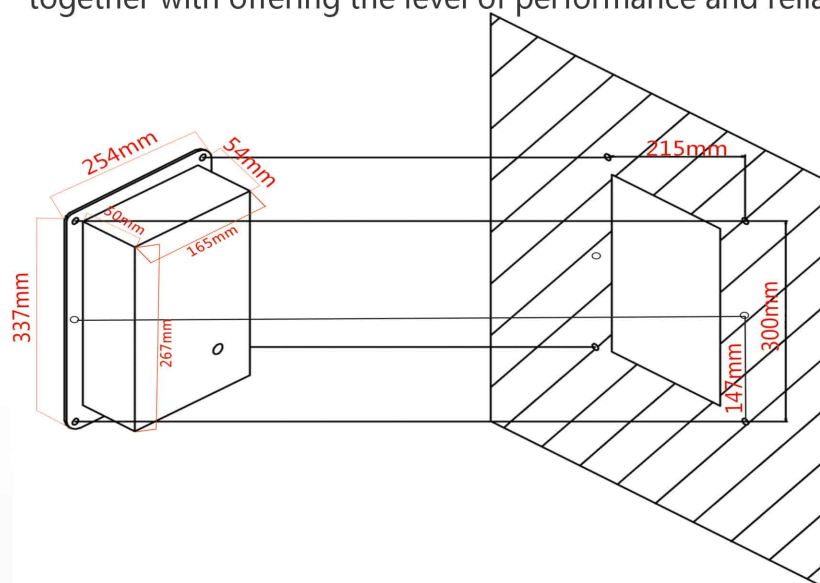

Main Product features

1. Analogue phone, hand free telephone, push for help
2. Metal body stainless steel 304 (we can make stainless steel 316 as optional).
3. Built-in 4 group of memory, sequence dial, if the first number doesn't answer dial to the next number
4. Auto answer and auto stop if the other side stopped
5. Remote or local modify speed dial telephone number
6. Built-in message record can be programmable, auto report location
7. LED indicator for dialing or answered to make sure seek help message received
8. Time out function to avoid line engaged
9. Handset free, with built-in loud speaker
10. Waterproof grade in IP55
11. Lighting protection to ITU-T K.21
12. The metal shell is provided with grounding
13. Mounting with stainless steel tamper proof screws against thief
14. Dry contact ready if customer need this for CCTV
15. With built-in camera (optional)
16. With external loud speaker (15w) for broadcast (optional)
17. Dry contact for External Camera (optional)

- Standard and SMART Analogue and VoIP-SIP options available
- DTMF(Dual Tone Multi Frequency)
- Matching with most PABX,PBX and PAX systems.

Main PCB

1. Well treated PCB used inside the phone.
2. Robust screw terminals used for the connection of ringer, handset, line in, hookswitch.
3. Selectable 7 minute time out, to release the line if the handset is left off hook.
4. All connectors be greased in production.

VOIC OVER IP- SIP (Version)

Connection type: RJ45 Socket inside sealed enclosure
Power supply: External 5V dc
Call set-up Protocol: Session Initiation Protocol(SIP)
Configuration: DHCP or STATIC IP address provisioning



The most professional manufacture in Asia
The exclusive supplier for all Metro project in China

Telephone layout

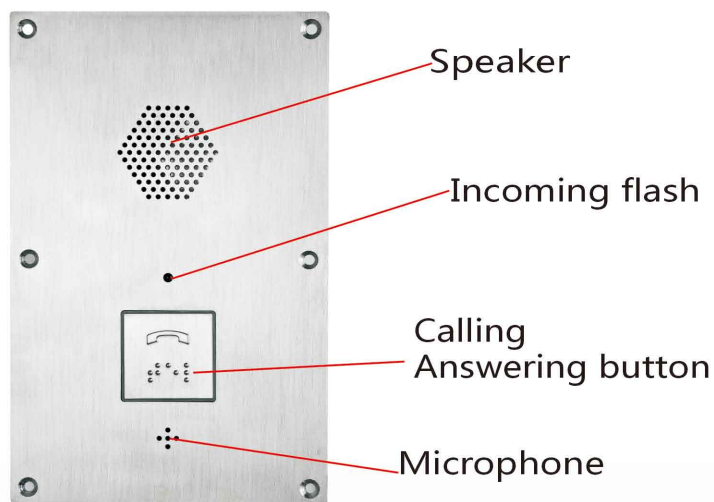

TECHNICAL SPECIFICATION

1. Applicable for various types of SPC exchange and dispatching exchange system with feeding voltage of 48-69V. Work with Pair cable.
2. Basis on PBX analogue telephone
3. Operating temperature:-10°C~ +55°C Relative humidity:10%~95% Atmospheric pressure: 86~106Kpa Circumstance noise:≤ 60dB (A)

The ERT assembly housing weather proof with an IP rating of IP554、 Sound level of ringing : ≥70dB (A) .5、 Power supply: DC 9-24V @ 200mA power supply or 9V DC battery or 8.4V Ni MH Battery
 Dial: DTMF
 Responses frequency : 550Hz-3400Hz, +/- 3db
 Operate loop impedance: 600 ohms

Mounting bracket

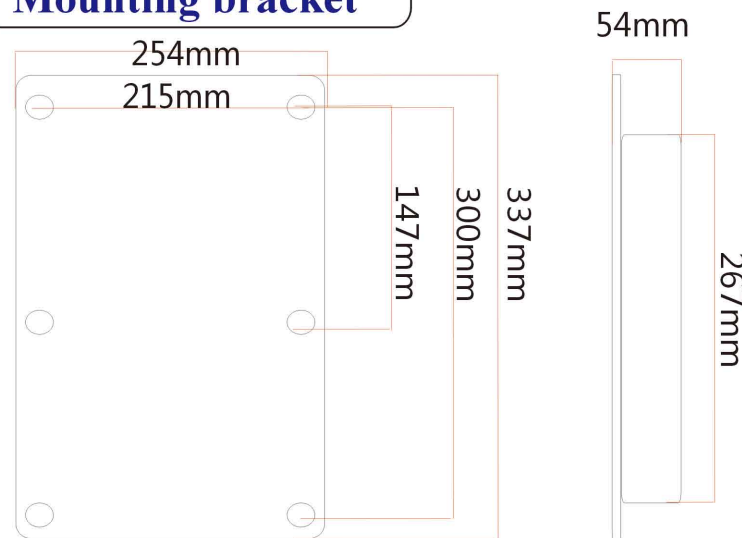

Connection cable

Stainless steel connection cable to exchange.
 Well treated keep waterproof.

Packing detail:

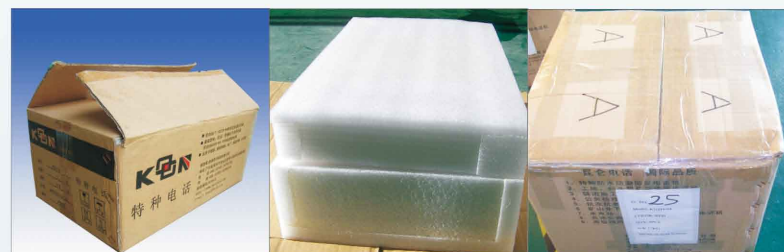

Unit size: 337*254*54mm , N.W: 2.3KG
 1pcs in each inner CTN box, size: 439 *277 *191mm G.W: 3KG
 4pcs in outer CTN box, size: 566 * 445 *420mm G.W: 13.3KG

Certification:



EMC: EN50121 (Railway application- Electromagnetic Compatibility)
 EN55022: emissions
 En55024: immunity
 FCC
 ITU-T Recommendations K21